

279/39

AGP

Magnetic Core Drill

SMD352 & SMD502

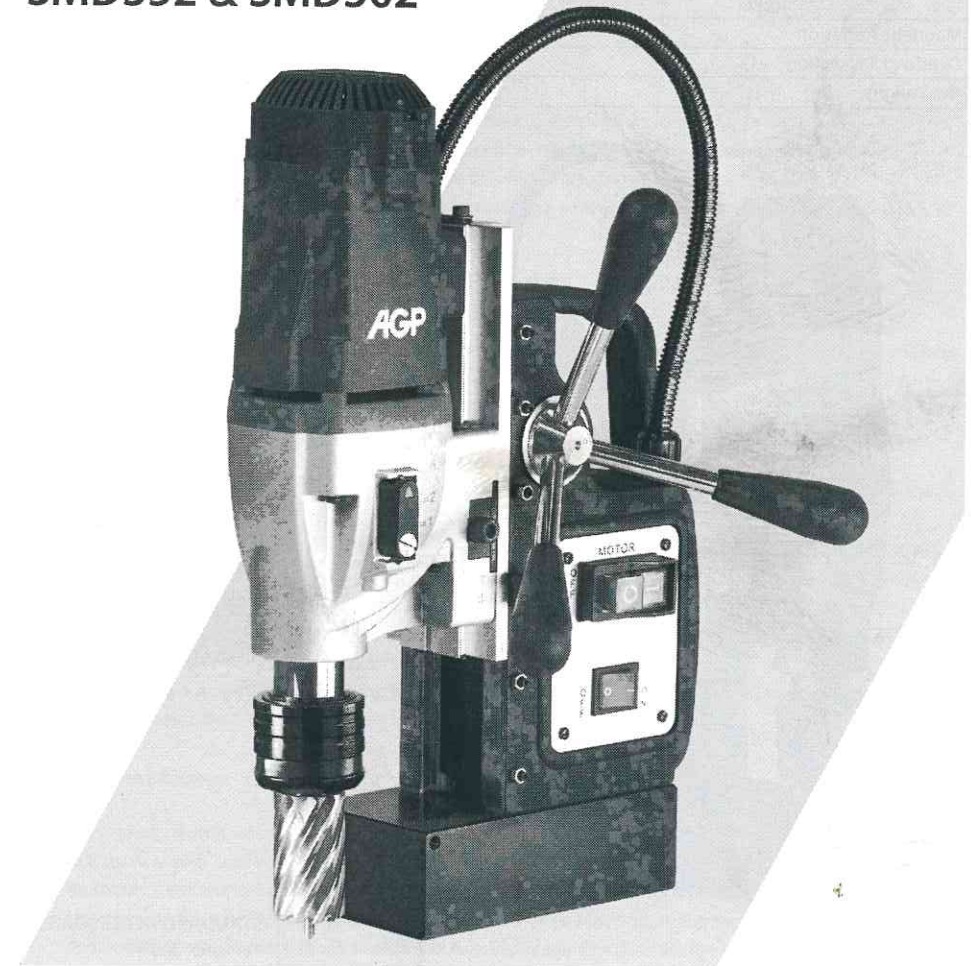

Instruction Manual
CE CB



TECHNICAL DATA

Model	SMD352		SMD502
Power Input	1100W		
Voltage	220-240 V~ 50-60 Hz, or 110-120 V~ 50-60 Hz (See Machine Nameplate)		
No./Full Load Min ⁻¹	Speed 1	450 / 270	300 / 180
	Speed 2	730 / 440	450 / 270
Capacity	Ø x Depth of Cut (Annular Cutters)	35 mm x 50 mm (1-3/8" x 2")	50 mm x 50 mm (2" x 2")
	Ø Twist Drills	≤ 12.7 mm (1/2") shank	
	Stroke	140 mm (5-1/2")	
Magnetic Adhesion	17,000 N		
Overload Protection	Optional		
Net Weight	14.8 kg (32.6 lb)		

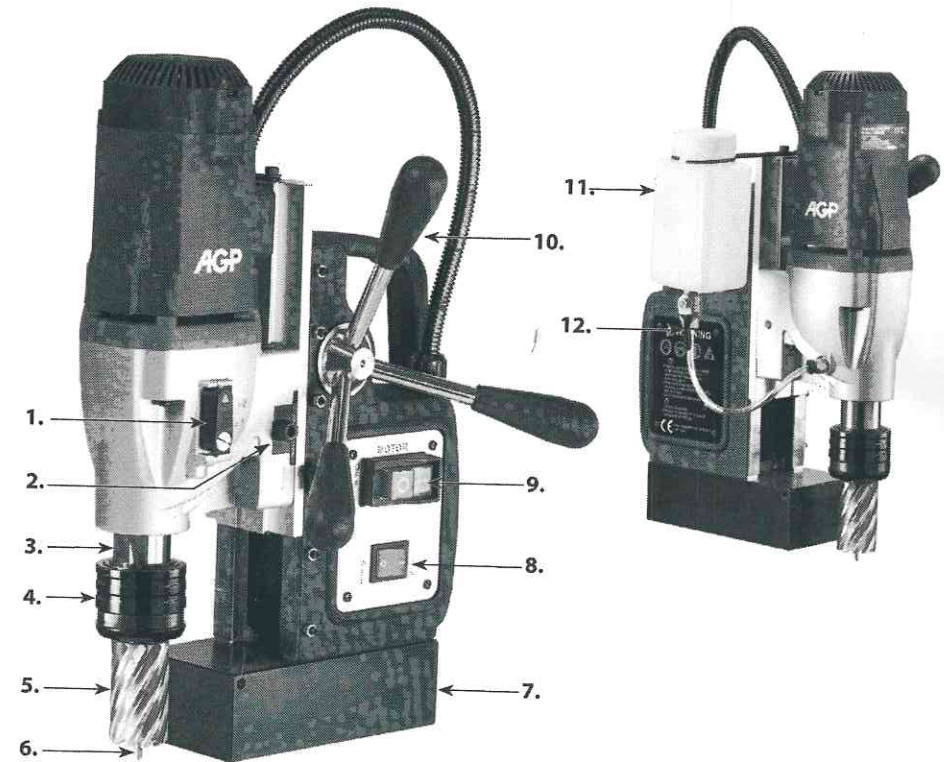

- 1. Gear selector
- 2. Slide Height Lock
- 3. Arbor
- 4. Quick-Release Tool Holder
- 5. Annular Cutter (Not Included)
- 6. Pilot Pin (Not Included)

- 7. Magnet Base
- 8. Magnet Switch
- 9. Motor Switch
- 10. Crank Handle
- 11. Coolant Tank
- 12. Coolant Feed Tap

STANDARD ACCESSORIES

- * Wrench M8
- * T-Wrench M6
- * L-Hex Key M2.5
- * L-Hex Key M4
- * Chip Guard kit
- * Coolant Tank kit
- * Safety Chain

GENERAL POWER TOOL SAFETY WARNINGS



WARNING Read all safety warnings, instructions, illustrations and specifications provided with this power tool. Failure to follow all instructions listed below may result in electric shock, fire and/or serious injury.

Save all warnings and instructions for future reference.

The term "power tool" in the warnings refers to your mains-operated (corded) power tool or battery-operated (cordless) power tool.

1) Work area safety

- a. **Keep work area clean and well lit.** Cluttered or dark areas invite accidents.
- b. **Do not operate power tools in explosive atmospheres, such as in the presence of flammable liquids, gases or dust.** Power tools create sparks which may ignite the dust or fumes.
- c. **Keep children and bystanders away while operating a power tool.** Distractions can cause you to lose control.

2) Electrical safety

- a. **Power tool plugs must match the outlet. Never modify the plug in any way. Do not use any adapter plugs with earthed (grounded) power tools.** Unmodified plugs and matching outlets will reduce risk of electric shock.
- b. **Avoid body contact with earthed or grounded surfaces, such as pipes, radiators, ranges and refrigerators.** There is an increased risk of electric shock if your body is earthed or grounded.
- c. **Do not expose power tools to rain or wet conditions.** Water entering a power tool will increase the risk of electric shock.
- d. **Do not abuse the cord. Never use the cord for carrying, pulling or unplugging the power tool. Keep cord away from heat, oil, sharp edges or moving parts.** Damaged or entangled cords increase the risk of electric shock.
- e. **When operating a power tool outdoors, use an extension cord suitable for outdoor use.** Use of a cord suitable for outdoor use reduces the risk of electric shock.
- f. **If operating a power tool in a damp location is unavoidable, use a residual current device (RCD) protected supply.** Use of an RCD reduces the risk of electric shock.

3) Personal safety

- a. **Stay alert, watch what you are doing and use common sense when operating a power tool. Do not use a power tool while you are tired or under the influence of drugs, alcohol or medication.** A moment of inattention while operating power tools may result in serious personal injury.
- b. **Use personal protective equipment. Always wear eye protection.** Protective equipment such as a dust mask, non-skid safety shoes, hard hat or hearing protection used for appropriate conditions will reduce personal injuries.
- c. **Prevent unintentional starting. Ensure the switch is in the off-position before connecting to power source and/or battery pack, picking up or carrying the tool.** Carrying power tools with your finger on the switch or energising power tools that have the switch on invites accidents.
- d. **Remove any adjusting key or wrench before turning the power tool on.** A wrench or a key left

attached to a rotating part of the power tool may result in personal injury.

- e. **Do not overreach. Keep proper footing and balance at all times.** This enables better control of the power tool in unexpected situations.
- f. **Dress properly. Do not wear loose clothing or jewellery. Keep your hair and clothing away from moving parts.** Loose clothes, jewellery or long hair can be caught in moving parts.
- g. **If devices are provided for the connection of dust extraction and collection facilities, ensure these are connected and properly used.** Use of dust collection can reduce dust-related hazards.
- h. **Do not let familiarity gained from frequent use of tools allow you to become complacent and ignore tool safety principles.** A careless action can cause severe injury within a fraction of a second.

4) Power tool use and care

- a. **Do not force the power tool. Use the correct power tool for your application.** The correct power tool will do the job better and safer at the rate for which it was designed.
- b. **Do not use the power tool if the switch does not turn it on and off.** Any power tool that cannot be controlled with the switch is dangerous and must be repaired.
- c. **Disconnect the plug from the power source and/or remove the battery pack, if detachable, from the power tool before making any adjustments, changing accessories, or storing power tools.** Such preventive safety measures reduce the risk of starting the power tool accidentally.
- d. **Store idle power tools out of the reach of children and do not allow persons unfamiliar with the power tool or these instructions to operate the power tool.** Power tools are dangerous in the hands of untrained users.
- e. **Maintain power tools and accessories. Check for misalignment or binding of moving parts, breakage of parts and any other condition that may affect the power tool's operation. If damaged, have the power tool repaired before use.** Many accidents are caused by poorly maintained power tools.
- f. **Keep cutting tools sharp and clean.** Properly maintained cutting tools with sharp cutting edges are less likely to bind and are easier to control.
- g. **Use the power tool, accessories and tool bits etc. in accordance with these instructions, taking into account the working conditions and the work to be performed.** Use of the power tool for operations different from those intended could result in a hazardous situation.
- h. **Keep handles and grasping surfaces dry, clean and free from oil and grease.** Slippery handles and grasping surfaces do not allow for safe handling and control of the tool in unexpected situations.

5) Service

Have your power tool serviced by a qualified repair person using only identical replacement parts. This will ensure that the safety of the power tool is maintained.

TERMINOLOGY USED IN THE MANUAL

- 1. **Warning:** This term means that there is a risk of physical harm or death to the operator or people nearby.
- 2. **Caution:** This term means that there is a risk of damage to the machine, cutting tool or other equipment.
- 3. **Note:** These terms offer useful information relating to the operation of the machine or its maintenance.

Symbols used in this manual

V.....volts
A.....amperes
Hz.....hertz
W.....watt
~.....alternating current
 n_0no load speed
min⁻¹.....revolutions or reciprocation
per minute

warning of general danger

with electrical earth

read these instructions

always wear eye protection

always wear a dust mask.

always wear hearing protection

wear safety-approved hard hat

 do not dispose of electric tools,
accessories and packaging together
with household waste material

DRILL SAFETY WARNINGS

- a. **The drill must be secured.** A drill that is not properly secured may move or tip over and may result in personal injury.
- b. **The workpiece must be clamped or secured to the workpiece support. Do not drill pieces that are too small to be clamped securely.** Holding the workpiece by hand during operation may result in personal injury.
- c. **Do not wear gloves.** Gloves may be entangled by the rotating parts or chips, leading to personal injury.
- d. **Keep your hands out of the drilling area while the tool is running.** Contact with rotating parts or chips may result in personal injury.
- e. **Make sure the accessory is rotating before feeding into the workpiece.** Otherwise the accessory may become jammed in the workpiece, causing unexpected movement of the workpiece and personal injury.
- f. **When the accessory is jammed, stop applying downward pressure and switch off the tool. Investigate and take corrective actions to eliminate the cause of the jam.** Jamming can cause unexpected movement of the workpiece and personal injury.
- g. **Avoid generating long chips by regularly interrupting downward pressure.** Sharp metal chips may cause entanglement and personal injuries.
- h. **Never remove chips from the drilling area while the tool is running. To remove chips, move the accessory away from the workpiece, switch off the tool, and wait for the accessory to stop moving. Use tools such as a brush or hook to remove chips.** Contact with rotating parts or chips may result in personal injury.
- i. **Accessories with speed ratings must be rated at least equal to the maximum speed marked on the power tool.** Accessories running faster than their rated speed can break and fly apart.

MAGNETIC DRILL SPECIFIC SAFETY WARNINGS AND CAUTIONS

- a. **Always use safety chain.** Mounting can release.
- b. **WARNING: While operating, only hold the crank handles, not any other part of the machine.** Placing the hand on the machine may result in an electric shock in the event of a voltage leak or if the machine cuts its own power supply cable.
- c. **Always ensure that the work piece is a minimum of 12mm (7/16 in.) thick. If it is not, then use a piece of steel plate at least 12mm thick and larger than the magnet, below the work piece, to supplement the magnetic adhesion.** The magnet's adhesion depends on the thickness of the work piece.
- d. **Do not operate the machine on a workpiece while it is being welded.** This may lead to damage to the machine and/or personal injury.
- e. **Never position machine on a work piece between the electrode and the ground of any arc type welder.** The welder's current will ground through the earth wire in the machine's power supply cable, causing it damage.
- f. **Do not exceed 90 degrees from horizontal.** It is hazardous to use the drill upside-down.
- g. **Always ensure that the magnet is clean and free of rust and scale.** Metal chips and other debris will hamper magnetic adhesion.
- h. **Always use the tool alone on the receptacle.** Other units used on the same receptacle could cause uneven voltage that could lead to the magnet releasing.
- i. **Ensure that the magnet has properly adhered to the work piece before beginning drilling.** Proper magnet adhesion is essential for safe drilling.
- j. **When drilling non-ferrous (non-magnetic) work materials, only use a manufacturer-approved fixture such as a vacuum base adapter.** Use of accessories which are not manufacturer-approved could result in a hazardous situation.
- k. **Do not operate with dull or damaged cutting tools.** This may overload the motor.
- l. **Avoid operating annular cutters without cutting fluid.** Always check fluid level before operating. Annular cutters require cutting fluid for proper operation and long life.
- m. **Protect the motor. Never allow cutting fluid, water, or other contaminants to enter the motor.** This could lead to electric shock or motor damage.
- n. **When drilling stacked work materials, always stop to clear the slug after the first layer is drilled.** The loose slug will interfere with proper drilling.
- o. **CAUTION: Never attempt to use machine with incorrect current or abnormally low voltage.** Incorrect voltage could lead to motor damage.
- p. **This machine is not intended for production-line type use.**

MAGNET BASE DUTY CYCLE

Do not leave the magnet base activated continuously for more than 60 minutes. If the magnet base is overheated, allow it to cool for 30 minutes before continuing.

CAUTION: Turn the magnet base off when not in use. Leaving the magnet base on continuously will damage it.

ASSEMBLY

Coolant tank assembly required. First attach clear tube to the bottom of the coolant tank. To do this, first loosen the nut and slide nut onto the tube. Then slide tube onto the nipple. Then tighten the nut. Slide tank hanger over the screw on the upper right hand side of slide and tighten. Finally insert the other end of the tube into the quick-release connector in the gearbox. Just directly push in to install. **(To remove, first firmly push the red collar of the connector and pull the tube out.)** Cutting coolant fluid is always required when using annular cutters. Open tank cover and fill. Check coolant fluid level often. Keep coolant tap closed when not in use.

Chip guard must be used. To attach the chip guard, use the supplied butterfly bolts to bolt to the magnet. It is not necessary to remove guard to clean chips. Simply raise guard to its upper position.

Safety chain must be used. Loop chain around the work piece and feed through the machine's handle and clip in place.

ADJUSTING THE SLIDE HEIGHT

Adjustable slide height models allow the operator to quickly change the height position of the motor head on the slide. This is useful when switching between twist drills and annular cutters, for example. For annular cutters, use the lowest position possible for best stability. For twist drills, raise the motor head to allow enough clearance for the twist drill to be mounted.

To adjust:

1. Using the T-handle hex wrench, loosen the socket cap screw on the Slide Height Lock.
2. Slide the motor head to the desired position.
3. Tighten the Slide Height Lock.

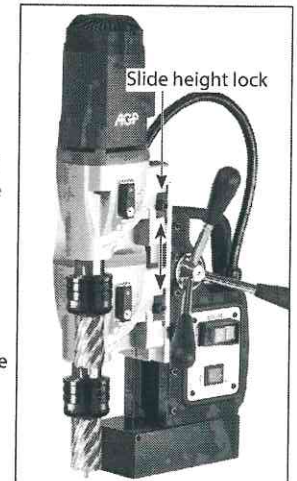

MOUNTING ANNULAR CUTTERS

CAUTION: Never use a cutting tool that is larger than the maximum rated capacity of the machine.

For set screw type arbors:

To insert an annular cutter, first insert the pilot pin into the cutter. Then slide the cutter into the arbor, align the proper flat with the locking screw(s) and tighten securely with the supplied L-hex key.



CAUTION: Ensure that the locking screw is on a flat of the cutter and not just against the rounded shank.

For quick-release type arbors:

Push up on the quick-release collar. Insert the cutter with pilot pin and turn

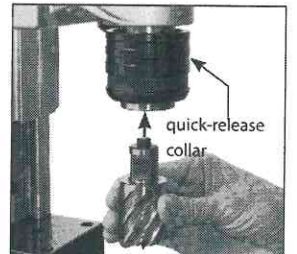

until the flat meets the locking pin. When the flat meets the locking pin, the collar will snap down. Double check to ensure that it is fully locked.

GEAR SELECTION

Before drilling, select the desired gear range by first swinging the gear selector tab out of the detent slot then shifting into the correct gear. Then pop the selector tab back into the detent. It will usually be necessary to turn the spindle by hand a little to get it to shift all the way.

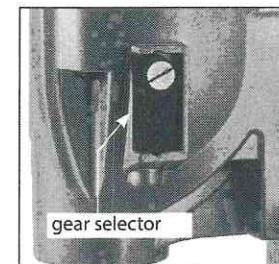

2 SPEED GEAR CHART

SMD352

GEAR	NO LOAD SPPEED	FULL LOAD SPEED	CUTTER SIZE
1	450 min ⁻¹	270 min ⁻¹	≤ 35 mm (1-3/8") HSS cutters
2	730 min ⁻¹	440 min ⁻¹	≤ 35 mm (1-3/8") TCT cutters

SMD502

GEAR	NO LOAD SPPEED	FULL LOAD SPEED	CUTTER SIZE
1	300 min ⁻¹	180 min ⁻¹	≤ 50 mm (2") HSS cutters
2	450 min ⁻¹	270 min ⁻¹	≤ 50 mm (2") TCT cutters

NOTE: These speeds are general recommendations only. Actual speeds should be determined by the material and the cutting speed recommended by the cutting tool manufacturer. See the section below "RECOMMENDED SURFACE SPEEDS" and use the formula to calculate the best RPM.

CAUTION: Ensure that that gears engage fully.

CAUTION: ALWAYS ensure that the machine is fully stopped before attempting to change gears! NEVER change gears on a running machine!

OPERATION-GENERAL

WARNING: Always ensure that the magnet is adhered properly to the work piece before beginning drilling.

NOTE: If mounting to a curved surface beam, mount the machine parallel to the curve in the work piece.
WARNING: Avoid operating at more than 90 degrees from horizontal. When drilling at such an angle take precautions to prevent cutting coolant from entering the motor. Paste-type coolant should be used.

1. First fit tool into arbor and line up with intended center of cut. Then switch magnet on.
2. Press green motor on button to start motor. Use the crank handle to feed to work. Always use very light

pressure when beginning the cut and just as the tool is breaking through. The crank handle offers tremendous leverage; so do not use too much force. Allow the cutting tool to determine the pace. With experience, the operator will be able to determine the best pace to feed to the work. There should be some degree of audible slowing of the motor but not bogging in the cut. Correct cutting speed with a properly sharp annular cutter will produce long unbroken chips, which produce a "bird's nest" shaped bundle of chips around the cut.

NOTE: Always ensure that the cutting tool is sharp. A dull cutter typically will have finer and/or choppy shavings.

WARNING: ALWAYS clear chips when there is too much build-up. Excessive chip build-up could result in a jammed cutter or other hazardous situation.

WARNING: the slug ejects at end of cut and is very hot. Always provide a method of catching the slug, where the ejected slug may cause injury to people below.

Note: Lock the slide lock on the side of the machine in the fully raised position when at rest to prevent the slide from accidentally slamming down - remember to unlock it again before commencing drilling.

CAUTION: Never attempt to cut half-circles or to stitch drill (drill overlapping holes) with a TCT cutter. This may destroy the cutter.

CAUTION: Never attempt to re enter a half-finished cut if the magnet has been turned off and the machine shifted in the interim. This may destroy the cutter.

CAUTION: Do not leave the magnet on for extended periods of time. This will lead to overheating of the coils and subsequent early failure. Only turn the magnet on when you are ready to drill and turn back off when you are done.

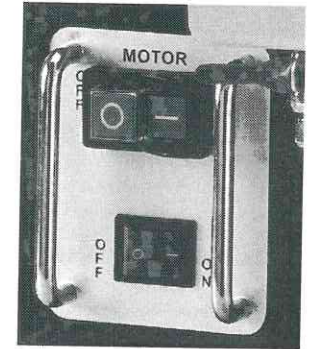

TWIST DRILLING

1. First mount the Chuck to the Chuck adaptor.
2. Then push up on the Quick-Release Collar. Insert the Chuck Adaptor into the Tool Holder and turn until the Quick-Release Collar snaps down.
3. Always double check to ensure that the Quick-Release Tool Holder is fully locked.
4. Insert the twist drill into the Chuck and tighten with the chuck key.

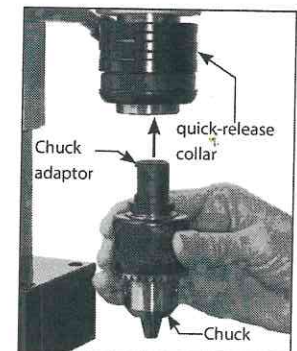

THE GIBS (DOVETAIL SLIDES)

The gibs require adjustment if too loose. To adjust, loosen the lock nuts and adjust the adjustor screws evenly while moving the handle up and down. Adjust so that there is no free play, without any binding anywhere in its range of travel. Then retighten the lock nuts. Periodically check, lubricate, and adjust as needed.



THE CARBON BRUSHES

The carbon brushes are a normal wearing part and must be replaced when they reach their wear limit.

Caution: Always replace the brushes as a pair.

To replace:

1. Remove the 4 screws and remove the motor tail cover.
2. Using pliers rotate the brush spring out of the way and slide the old carbon brush out of the brush holder.
3. Unscrew the screw to remove the brush lead. The old carbon brush may now be lifted away.
4. Install a new brush. Installation is the reverse of removal.
5. Replace the motor tail cover.



CARBON BRUSHES

Due to the brush design, if the machine comes to a stop without any reason, the brushes have to be checked. The brush design stops the machine before the carbon brushes are finished and protects the motor.

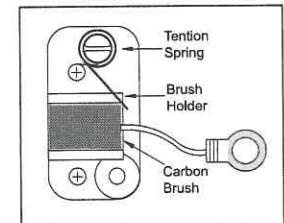

MAGNET TROUBLESHOOTING

Full magnet performance is absolutely essential for magnetic drill operation.

If the magnet works, but does not hold well, it is likely that one of the coils has failed. If the magnet does not work at all, it is likely to be a failed rectifier. (It is highly unlikely that both magnet coils would fail at the same time)

NOTE: A faulty magnet coil can also damage the rectifier, so whenever there is a magnet problem, BOTH the magnet coils and rectifier must be checked.

WARNING: Never attempt to operate a magnetic drill with a faulty magnet!

CHECKING THE MAGNET (qualified technicians only)

If the magnet is not working well, it must be checked. Separate the wires of each individual coil and test the resistance of each coil separately. (note that 110V models are wired in parallel and 230V models are wired in series) The resistance of the coils of different sizes of magnets varies, but it should be in the region of hundreds of ohms. Most importantly, both coils must have very nearly the same resistance. If one of the coils has zero resistance, it means that it is shorted. If one of the coils has infinite resistance, it means that the circuit is broken. If either coil has a problem, the magnet must be replaced. A faulty magnet may also cause damage to the rectifier. Also check the rectifier when replacing a faulty magnet. (see below)

CHECKING THE RECTIFIER (Qualified technicians only)

The rectifier takes the AC household current and converts it to DC to power the magnet. If it fails, the magnet coils will not receive power.

Disconnect the rectifier and test the resistance of both circuits of the rectifier between the AC and the DC sides. Note that polarity matters, so you can only take a reading if test probes are oriented correctly. Each side will be the opposite of the other. Both circuits should have very nearly the same resistance reading. If one of the circuits has zero resistance, it means that it is shorted. If one of the circuits has infinite resistance, it means that the circuit is broken.

If the replacement of the power supply cord is necessary, this has to be done by the manufacturer or their agent in order to avoid a safety hazard.

WARNING: All repairs must be entrusted to an authorized service center. Incorrectly performed repairs could lead to injury or death.

EXPLODED VIEW & PARTS LIST (SMD352)

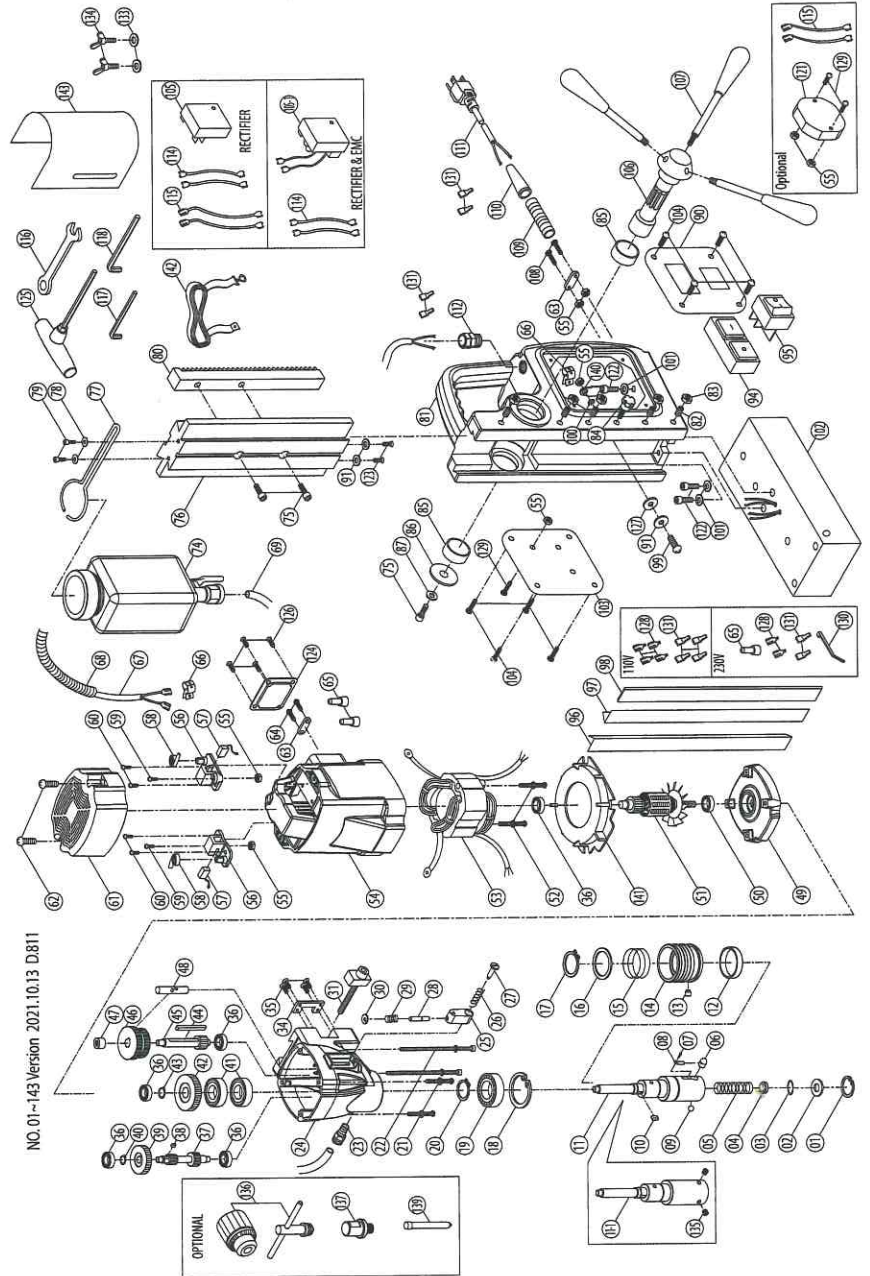

NO.01~143 Version 2021.10.13 D.811

NO.	Parts Name	Q'TY	NO.	Parts Name	Q'TY
1	INTERNAL CIRCLIP (R-19)	1	67	WIRE (1.25x2Cx65CM-VCTF)	1
2	FLAT WASHER (Ø10xØ18.5x0.8)	1	68	CABLE PROTECTOR (5/16"x40CM)	1
3	O-RING (Ø12x4)	1	69	TUBE (Ø4xØ6x20CM)	1
4	WATER SEAL (Ø12x15)	1	74	COOLANT TANK ASSEMBLY	1
5	SPRING (Ø1.2xØ10.1xØ12.5x12TxØ5L)	1	75	SOCKET CAP SCREW (M6x16xP1.0)	3
6	LOCK PIN (12.3MM)/(11.7MM)	1	76	SLIDE PLATE (L217MM)	1
7	PANHEAD MACHINE SCREW (M3x4xP0.5)	1	77	COOLANT TANK BRACKET	1
8	LOCK PIN SPRING	1	78	FLAT WASHER (Ø5xØ12x1)	2
9	CHECK BALL (Ø8)	1	79	SOCKET CAP SCREW (M5x16xP0.8)	2
10	PARALLEL KEY (5x5x10)	1	80	GEAR RACK (M1.5x150L)	1
11	SPINDLE (194.5MM)	1	81	STAND BODY	1
11-1	SPINDLE	1	82	SOCKET SET SCREW (M5x20xP0.8)	5
12	RING (Ø40xØ44x9)	1	83	HEX NUT (M5xP0.8)	5
13	COLLAR PIN (Ø8)	1	84	THUMB SCREW (M5x16)	1
14	QUICK-RELEASE COLLAR	1	85	BUSHING (Ø28xØ32x12)	2
15	SPRING (Ø2.3xØ39xØ43.6x3Tx30L)	1	86	FLAT WASHER (Ø6xØ40x2.5)	1
16	SPRING SEAT RING (Ø35.1xØ44.5x2)	1	87	FLAT WASHER (Ø6xØ25x1)	1
17	EXTERNAL CIRCLIP (S-35)	1	90	SWITCH PANEL (90x110x1.5T)	1
18	INTERNAL CIRCLIP (R-47)	1	91	FLAT WASHER (Ø4xØ10x1)	3
19	BALL BEARING (6005)	1	94	MOTOR SWITCH (110V/220V)	1
20	EXTERNAL CIRCLIP (S-25)	1	95	MAGNET SWITCH (110V&220V)	1
21	PANHEAD TAPPING SCREW (M5x65)	2	96	GIB STRIP-LEFT (258MM)	1
22	PANHEAD TAPPING SCREW (M5x110)	2	97	GIB STRIP-RIGHT (258MM)	1
23	PUSH LOCK FITTING (PT1/8"xØ6)	1	98	GIB TENSIONER (258x11x1.2T)	1
24	GEAR HOUSING	1	99	PANHEAD MACHINE SCREW (M4x16xP0.7)	1
25	SELECTOR TAB	1	100	EXTERNAL STAR WASHER (M5)	1
26	SPRING (Ø1xØ9xØ11x11Lx4T)	1	101	SPRING WASHER (M6)	3
27	SHOULDER SCREW	1	102	ELECTROMAGNET (176x90x55.5)	1
28	DETENT PIN (Ø5x22)	1	103	SIDE PANEL (110x90x1.5T)	1
29	SPRING (Ø0.6xØ5.3xØ6.5x17Lx5T)	1	104	PANHEAD MACHINE SCREW (M4x8xP0.7)	8
30	E-CLIP (E-3)	1	105	RECTIFIER (110&220V)	1
31	SLIDE HEIGHT LOCK	1	105-1	RECTIFIER & EMC (110V)/(110V&220V)	1
34	LOCK BRACKET	1	106	CRANK SPINDLE (Ø28)	1
35	FLAT HEAD MACHINE SCREW (M4x10xP0.7)	4	107	CRANK HANDLE	3
36	BALL BEARING (608)	5	108	PANHEAD MACHINE SCREW (M4x30xP0.7)	2
37	INPUT SHAFT (M1.0x12Tx17T)	1	109	CABLE PROTECTOR (5/16"x7CM)	1
38	PARALLEL KEY (4x4x8)	1	110	CORD ARMOR	1
39	INPUT GEAR (M1.0x36T)	1	111	POWER SUPPLY CABLE	1
40	EXTERNAL CIRCLIP (S10)	1	112	CABLE GLAND (5/16")	1
41	OIL SEAL (Ø25xØ40x7)	2	114	WIRE LEAD (1015-16#18CM)	2
42	OUTPUT GEAR (M1.25x37T)	1	115	WIRE LEAD (1015-16#18CM)	4
43	EXTERNAL CIRCLIP (S-15)	1	116	COMBINATION WRENCH (M8)	1
44	PARALLEL KEY (5x5x50)	1	117	HEX KEY (M2.5)	1
45	COUNTERSHAFT (M1.25x12T)	1	118	HEX KEY (M4)	1
46	LAY GEAR (M1.0x45Tx40T)	1	121	OVER LOAD PROTECTION (110V/220V)	1
47	NEEDLE BEARING (HK 0810)	1	122	SOCKET CAP SCREW (M6x20xP1.0)	3
48	SELECTOR FORK (Ø10x50 / Ø4.8x26)	1	123	TRUSS HEAD MACHINE SCREW (M4x6xP0.7)	2
49	GEAR PLATE	1	124	MOTOR COVER PLATE	1
50	BALL BEARING (6001)	1	125	T-HANDLE HEX KEY (M6)	1
51	ARMATURE (110V/220V-73x42x45)	1	126	FLAT HEAD TAPPING SCREW (M4x8)	4
52	PANHEAD TAPPING SCREW-B-W/WASHER (M5x60)	2	127	RUBBER WASHER (Ø4xØ11x1)	1
53	STATOR (110V/220V-73x42x45)	1	128	FEMALE SPADE TERMINAL	4
54	MOTOR HOUSING	1	129	PANHEAD MACHINE SCREW (M4x25xP0.7)	3
55	HEX NUT (M4xP0.7)	8	130	ZIP TIE (2.4x80MM)	1
56	CARBON BRUSH HOLDER (7x11)	2	131	SPADE TERMINAL BOOT	8
57	CARBON BRUSH (7x11x17)	2	133	FLAT WASHER (Ø6xØ13x1)	2
58	BRUSH SPRING (Ø.35x3x3T)	2	134	BUTTERFLY SCREW (M6x10xP1.0)	2
59	PANHEAD MACHINE SCREW (M4x10xP0.7)	2	135	SOCKET SET SCREW (M8x7xP1.25)	2
60	PANHEAD TAPPING SCREW (M4x12)	4	136	CHUCK (1/2")	1
61	MOTOR TAIL CASTING	1	137	QUICK-RELEASE CHUCK ADAPTORS (1/2")	1
62	PANHEAD TAPPING SCREW (M4x25)	2	139	PILOT PIN	1
63	CABLE CLIP	2	140	EARTHING MARKING	1
64	PANHEAD TAPPING SCREW (M4x14)	2	141	FAN SHROUD	1
65	CRIMP CAP CONNECTOR (C4)	3	142	SAFETY BELT	1
66	CABLE CLAMP	2	143	CHIP GUARD	1

EXPLODED VIEW & PARTS LIST (SMD502)

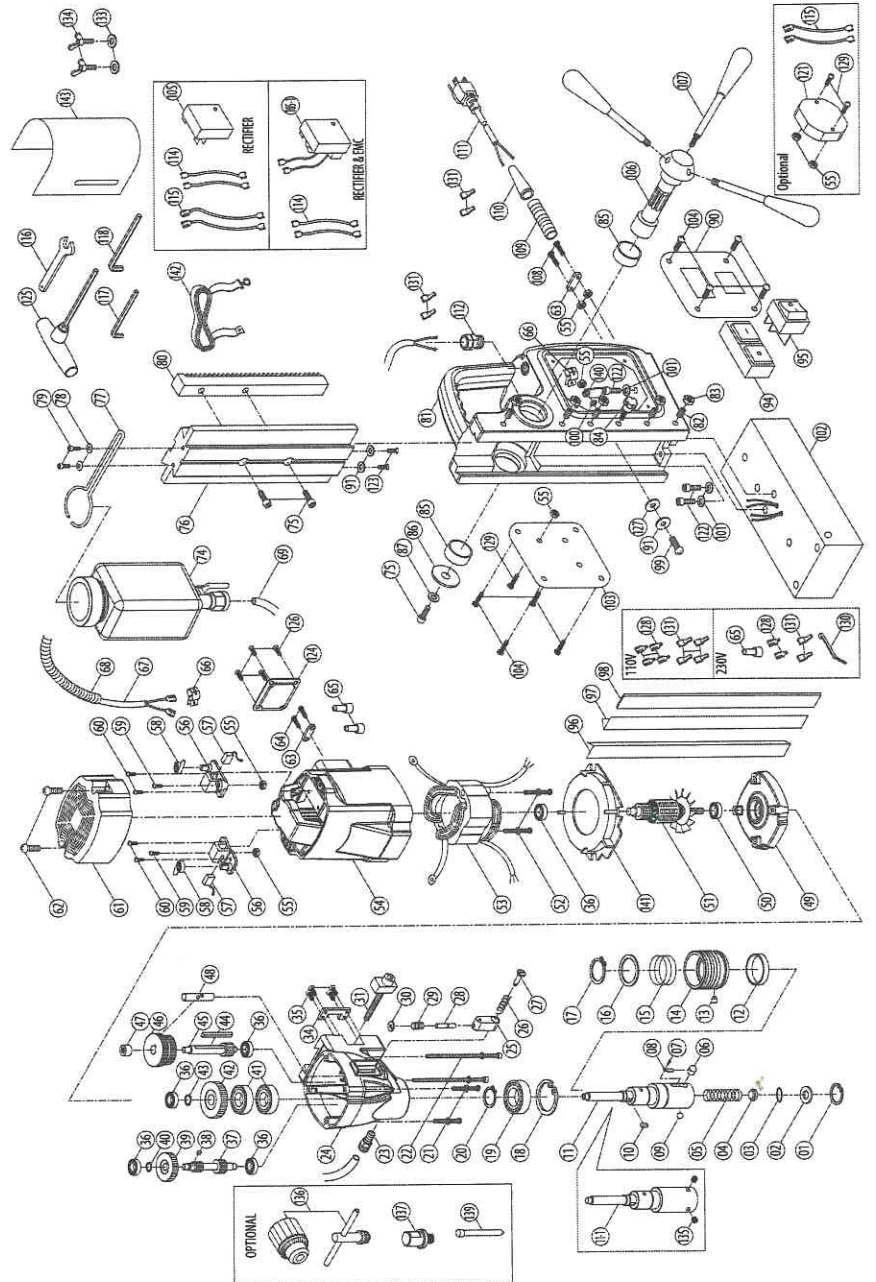

NO.	Parts Name	Q'TY	NO.	Parts Name	Q'TY
1	INTERNAL CIRCLIP (R-19)	1	67	WIRE (1.25x2Cx65CM-VCTF)	1
2	FLAT WASHER (Ø10xØ18.5x0.8)	1	68	CABLE PROTECTOR (5/16"x40CM)	1
3	O-RING (Ø12x4)	1	69	TUBE (Ø4xØ6x20CM)	1
4	WATER SEAL (Ø12x15)	1	74	COOLANT TANK ASSEMBLY	1
5	SPRING (Ø1.2xØ10.1xØ12.5x12Tx85L)	1	75	SOCKET CAP SCREW (M6x16xP1.0)	3
6	LOCK PIN (12.3MM)/(11.7MM)	1	76	SLIDE PLATE (L217MM)	1
7	PANHEAD MACHINE SCREW (M3x4xP0.5)	1	77	COOLANT TANK BRACKET	1
8	LOCK PIN SPRING	1	78	FLAT WASHER (Ø5xØ12x1)	2
9	CHECK BALL (Ø8)	1	79	SOCKET CAP SCREW (M5x16xP0.8)	2
10	PARALLEL KEY (5x5x10)	1	80	GEAR RACK (M1.5x150L)	1
11	SPINDLE (194.5MM)	1	81	STAND BODY	1
11-1	SPINDLE	1	82	SOCKET SET SCREW (M5x20xP0.8)	5
12	RING (Ø40xØ44x9)	1	83	HEX NUT (M5xP0.8)	5
13	COLLAR PIN (Ø8)	1	84	THUMB SCREW (M5x16)	1
14	QUICK-RELEASE COLLAR	1	85	BUSHING (Ø28xØ32x12)	2
15	SPRING (Ø2.3xØ39xØ43.6x3Tx30L)	1	86	FLAT WASHER (Ø6xØ40x2.5)	1
16	SPRING SEAT RING (Ø35.1xØ44.5x2)	1	87	FLAT WASHER (Ø6xØ25x1)	1
17	EXTERNAL CIRCLIP (S-35)	1	90	SWITCH PANEL (90x110x1.5T)	1
18	INTERNAL CIRCLIP (R-47)	1	91	FLAT WASHER (Ø4xØ10x1)	3
19	BALL BEARING (6005)	1	94	MOTOR SWITCH (110V/220V)	1
20	EXTERNAL CIRCLIP (S-25)	1	95	MAGNET SWITCH (110V&220V)	1
21	PANHEAD TAPPING SCREW (M5x65)	2	96	GIB STRIP-LEFT (258MM)	1
22	PANHEAD TAPPING SCREW (M5x110)	2	97	GIB STRIP-RIGHT (258MM)	1
23	PUSH LOCK FITTING (PT1/8"xØ6)	1	98	GIB TENSIONER (258x11x1.2T)	1
24	GEAR HOUSING	1	99	PANHEAD MACHINE SCREW (M4x16xP0.7)	1
25	SELECTOR TAB	1	100	EXTERNAL STAR WASHER (M5)	1
26	SPRING (Ø1xØ9xØ11x11Lx4T)	1	101	SPRING WASHER (M6)	3
27	SHOULDER SCREW	1	102	ELECTROMAGNET (176x90x55.5)	1
28	DETENT PIN (Ø5x22)	1	103	SIDE PANEL (110x90x1.5T)	1
29	SPRING (Ø0.6xØ5.3xØ6.5x17Lx5T)	1	104	PANHEAD MACHINE SCREW (M4x8xP0.7)	8
30	E-CLIP (E-3)	1	105	RECTIFIER (110&220V)	1
31	SLIDE HEIGHT LOCK	1	105-1	RECTIFIER & EMC (110V)/(110V&220V)	1
34	LOCK BRACKET	1	106	CRANK SPINDLE (Ø28)	1
35	FLAT HEAD MACHINE SCREW (M4x10xP0.7)	4	107	CRANK HANDLE	3
36	BALL BEARING (608)	5	108	PANHEAD MACHINE SCREW (M4x30xP0.7)	2
37	INPUT SHAFT (M1.0x11Tx15T)	1	109	CABLE PROTECTOR (5/16"x7CM)	1
38	PARALLEL KEY (4x4x8)	1	110	CORD ARMOR	1
39	INPUT GEAR (M1.0x36T)	1	111	POWER SUPPLY CABLE	1
40	EXTERNAL CIRCLIP (S10)	1	112	CABLE GLAND (5/16")	1
41	OIL SEAL (Ø25xØ40x7)	2	114	WIRE LEAD (1015-16#18CM)	2
42	OUTPUT GEAR (M1.25x39T)	1	115	WIRE LEAD (1015-16#18CM)	4
43	EXTERNAL CIRCLIP (S-15)	1	116	WRENCH (M8)	1
44	PARALLEL KEY (5x5x50)	1	117	HEX KEY (M2.5)	1
45	COUNTERSHAFT (M1.25x10T)	1	118	HEX KEY (M4)	1
46	LAY GEAR (M1.0x46Tx42T)	1	121	OVER LOAD PROTECTION (110V/220V)	1
47	NEEDLE BEARING (HK 0810)	1	122	SOCKET CAP SCREW (M6x20xP1.0)	3
48	SELECTOR FORK (Ø10x50 / Ø4.8x26)	1	123	TRUSS HEAD MACHINE SCREW (M4x6xP0.7)	2
49	GEAR PLATE	1	124	MOTOR COVER PLATE	1
50	BALL BEARING (6001)	1	125	T-HANDLE HEX KEY (M6)	1
51	ARMATURE (110V/220V-73x42x45)	1	126	FLAT HEAD TAPPING SCREW (M4x8)	4
52	PANHEAD TAPPING SCREW (M5x60)	2	127	RUBBER WASHER (Ø4xØ11x1)	1
53	STATOR (110V/220V-73x42x45)	1	128	FEMALE SPADE TERMINAL	4
54	MOTOR HOUSING	1	129	PANHEAD MACHINE SCREW (M4x25xP0.7)	3
55	HEX NUT (M4xP0.7)	8	130	ZIP TIE (2.4x80MM)	1
56	CARBON BRUSH HOLDER (7x11)	2	131	SPADE TERMINAL BOOT	8
57	CARBON BRUSH (7x11x17)	2	133	FLAT WASHER (Ø6xØ13x1)	2
58	BRUSH SPRING (Ø.35x3x3T)	2	134	BUTTERFLY SCREW (M6x10xP1.0)	2
59	PANHEAD MACHINE SCREW (M4x10xP0.7)	2	135	SOCKET SET SCREW (M8x7xP1.25)	2
60	PANHEAD TAPPING SCREW (M4x12)	4	136	CHUCK (1/2")	1
61	MOTOR TAIL CASTING	1	137	QUICK-RELEASE CHUCK ADAPTORS (1/2')	1
62	PANHEAD TAPPING SCREW (M4x25)	2	139	PILOT PIN (HSSx77LxØ6.34)	1
63	CABLE CLIP	2	140	EARTHING MARKING	1
64	PANHEAD TAPPING SCREW (M4x14)	2	141	FAN SHROUD	1
65	CRIMP CAP CONNECTOR (C4)	3	142	SAFETY BELT	1
66	CABLE CLAMP	2	143	CHIP GUARD	1

WIRING

